



**SPRING LAKE TOWNSHIP
SEWER SYSTEM
RULES & REGULATIONS**

SPRING LAKE TWP WASTEWATER COLLECTION SYSTEM

RULES FOR SEWER SERVICE

1. CONNECTION AND USE: Connection to the sewer system and use of the sewer system is governed by Township Ordinance No. 45. See this ordinance for regulations governing use of the sewer system and penalties for violation of the ordinance.
2. APPLICATION FOR CONNECTION: Application forms for connection are available in the Township Office. These forms will provide for payment of an inspection fee at the time request is made for service.
3. SEWER SERVICE INSTALLATION:
 - a. Service line material: PVC sewer pipe ASTM D-2665, Schedule 40 with purple primer ASTM F656-80 with solvent welded joints. Lines which are 6" or larger may be SDR 35.
 - b. Size and Grade:
 - 1) 4" minimum for single family & duplex homes, laid at a minimum grade of 1.00% (1 foot per 100 feet) from the lateral stub at the property line to the building.
 - 2) All others sized according to 2006 Michigan Plumbing Code laid at a minimum grade of 0.60% (6/10 of a foot per 100 feet) from the lateral stub at the property line to the building.
 - 3) New service shall be connected to cast iron or Schedule 40 PVC and drop to a minimum depth of 30". Under sidewalks or driveways shall be 5 foot deep.
 - 4) Bedding - pipe must be firmly supported and covered with compacted sand over its full length.
 - c. Cleanouts shall be placed:
 - 1) Within 5 feet of the building and spaced 100' apart. (Maximum)
 - 2) At all bends totaling 90 or greater.
 - 3) 90 bends must be made up of two 45 bends.
 - 4) Must use 'Y' where line connects to sewer stub (so plug can be inserted for pressure testing.)
 - d. Adapters for size changes and/or types of pipes shall be approved by the Township. 6" x 4" solvent weld bushing or coupling. Must use purple primer ASTM F656-80. 6 x 4" Fernco also approved.
 - e. Inspection manholes are required by the Grand Haven/Spring Lake Sewer Authority to monitor flow of industrial and/or commercial users before entering the public sewer system.
4. ACCEPTANCE TESTS: Air test or water test will be required for all sewer service installations. 5 pounds for 10 minutes. Installer shall provide and operate test equipment.

5. **INSURANCE:** Installer shall have \$100,000 Property Damage and \$100,000 Personal Liability. Liability insurance must cover excavation and underground construction. A copy of your current insurance certificate must be on file at the Township Hall.
6. **INSPECTION:** The Township shall be notified and shall inspect the installation prior to the pipe being covered. Inspection fees established in the rate ordinance apply. Charges for sewer use will commence at the time of connection to sewer stub.
7. **REPEAT INSPECTIONS:** If additional inspection visits are necessary, you will be charged an inspection fee for each visit. Be sure your work is complete and ready for inspection.
8. **SEPTIC TANKS:** "State Environmental Health Agency Rules and Regulations", states that septic tanks shall be pumped and filled with sand.
9. **DRAWINGS:** Please fill out attached sheet. Drawing **MUST** be returned to the Township Office as soon as service is completed. Drawings are filed for future reference by home owner, contractors, plumbers.

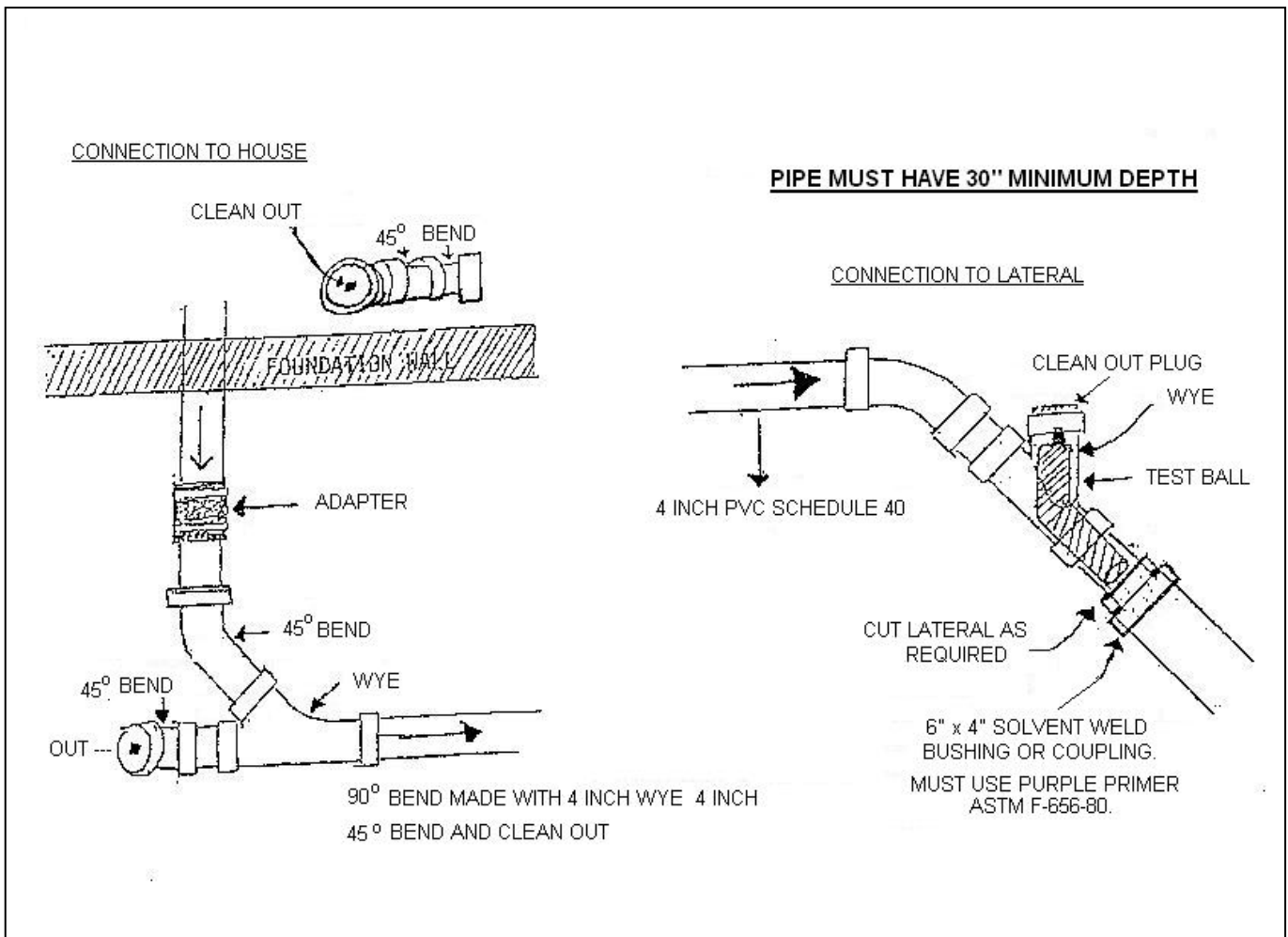

SPRING LAKE TOWNSHIP

SEWER LINE INSTRUCTIONS:

1. Make proper lines to designate sewer from house building drain to sewer lead at street.
2. Denote all clean-outs with measurements from house.

3. House Address: _____



STREET

WATER/SEWER LINE INSTALLERS

BEECHAM PLUMBING

6410 Johnson
Fruitport, MI 49415
Office (231)865-3072
Emergency cell (231)206-7441

TILES EXCAVATING

16958 144th Ave
Nunica, MI 49448
(616) 846-6500

BILZ PLUMBING

235 Second Street
Spring Lake, MI 49456
842-1336

NORTHERN PIPELINE CONTRACTORS

16891 148TH Ave
Spring Lake, Mi 49456
842-4614

TRI-CITY BACKHOE

15315 Kelly St
Spring Lake, MI 49456
846-9078

VANDENBERG EXCAVATING

16630 Ferris St
Grand Haven, MI 49417
846-6178

WEST MICHIGAN SEPTIC (Sewer only)

1043 Robbins Rd
Grand Haven, MI 49417
847-1072

WACHTER EXCAVATING

16580 144TH Ave
Spring Lake, MI 49456
842-1715

SPRING LAKE TOWNSHIP WATER/SEWER DEPT 616-842-0080